

Description

The DL0524P5A is an ultra low capacitance TVS array, utilizing leading monolithic silicon technology to provide fast response time and low ESD clamping voltage, making this device an ideal solution for protecting voltage sensitive high-speed data lines. The DL0524P5A complies with the IEC 61000-4-2 (ESD) with $\pm 20\text{kV}$ air and $\pm 15\text{kV}$ contact discharge. It is assembled into a 10-pin 2.5x1.0x0.5mm lead-free DFN package. The flow through style package allows for easy PCB layout and matched trace lengths necessary to maintain consistent impedance between high speed differential lines such as USB 3.0 and HDMI. The small size, ultra-low capacitance and high ESD surge protection make DL0524P5A an ideal choice to protect HDMI, MDDI, USB 3.0 and other high speed ports.

Mechanical Characteristics

- ◆ Package: DFN2510-10 (2.5 x1.0 x0.5mm)
- ◆ Lead Finish: Matte Tin
- ◆ Case Material: "Green" Molding Compound
- ◆ Moisture Sensitivity: Level 3 per J-STD-020
- ◆ Terminal Connections: See Diagram Below
- ◆ Marking Information: See Below

Dimensions and Pin Configuration

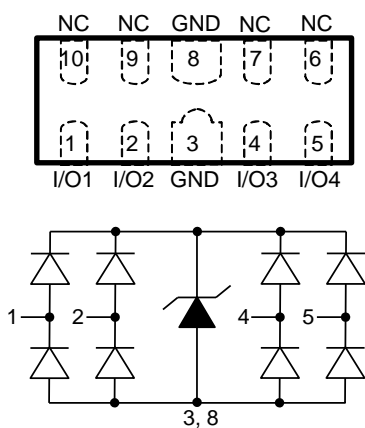

Circuit and Pin Schematic

Ordering Information

Part Number	Marking	Packaging	Reel Size
DL0524P5A	0524P	3000/Tape & Reel	7 inch

Features

- ◆ Ultra low capacitance: 0.25pF typical (I/O to I/O)
- ◆ Ultra low leakage: nA level
- ◆ Low operating voltage: 5V
- ◆ Low clamping voltage
- ◆ Up to 4 lines protects
- ◆ Complies with following standards:
 - IEC 61000-4-2 (ESD) immunity test
 - Air discharge: $\pm 20\text{kV}$
 - Contact discharge: $\pm 15\text{kV}$
 - IEC61000-4-5 (Lightning) : 4A(8/20 μs)
- ◆ ROHS Compliant

Applications

- ◆ HDMI 1.3 & 1.4, USB 2.0 & 3.0 and MDDI ports
- ◆ Monitors and flat panel displays
- ◆ Set-top box and digital TV
- ◆ Video graphics cards
- ◆ HDMI 2.0
- ◆ Digital video interface(DVI)
- ◆ Notebook Computers
- ◆ PCI express and Serial SATA ports

Marking Information

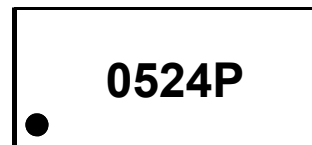

0524P =Device Marking Code
Dot denotes Pin1

Absolute Maximum Ratings ($T_A=25^{\circ}\text{C}$ unless otherwise specified)

Parameter	Symbol	Value	Unit
Peak Pulse Power (8/20 μs)	Ppk	60	W
Peak Pulse Current (8/20 μs)	I _{PP}	4	A
ESD per IEC 61000-4-2 (Air)	V _{ESD}	± 20	kV
ESD per IEC 61000-4-2 (Contact)		± 15	
Operating Temperature Range	T _J	-55 to +125	$^{\circ}\text{C}$
Storage Temperature Range	T _{stg}	-55 to +150	$^{\circ}\text{C}$

Electrical Characteristics ($T_A=25^{\circ}\text{C}$ unless otherwise specified)

Parameter	Symbol	Min	Typ	Max	Unit	Test Condition
Reverse Working Voltage	V _{RWM}			5	V	Any I/O pin to ground
Breakdown Voltage	V _{BR}	6			V	I _T = 1mA, any I/O pin to ground
Reverse Leakage Current	I _R			0.5	μA	V _{RWM} = 5V, any I/O pin to ground
Clamping Voltage	V _C			10	V	I _{PP} = 1A (8 x 20 μs pulse), any I/O pin to ground
Clamping Voltage	V _C			15	V	I _{PP} = 4A (8 x 20 μs pulse), any I/O pin to ground
Junction Capacitance	C _J		0.25	0.30	pF	V _R = 0V, f = 1MHz, between I/O pins
Junction Capacitance	C _J			0.50	pF	V _R = 0V, f = 1MHz, any I/O pin to ground

Typical Performance Characteristics (TA=25°C unless otherwise Specified)

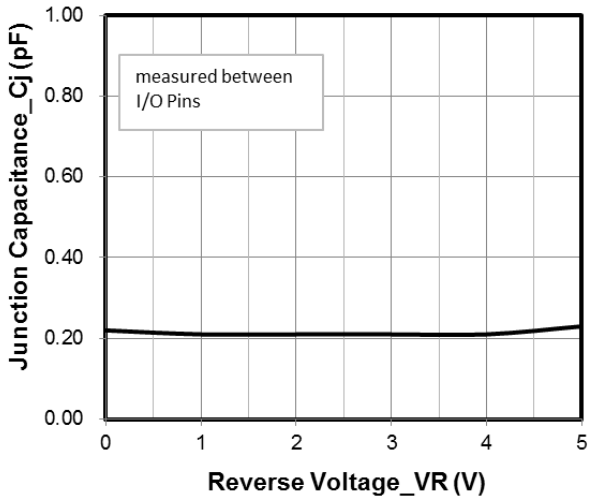

Junction Capacitance vs. Reverse Voltage

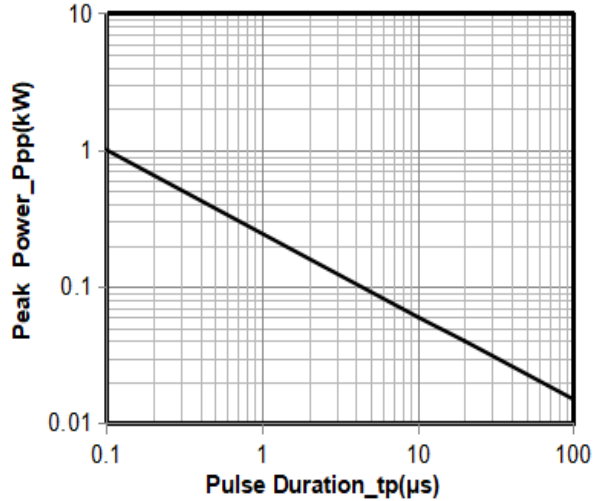

Peak Pulse Power vs. Pulse Time

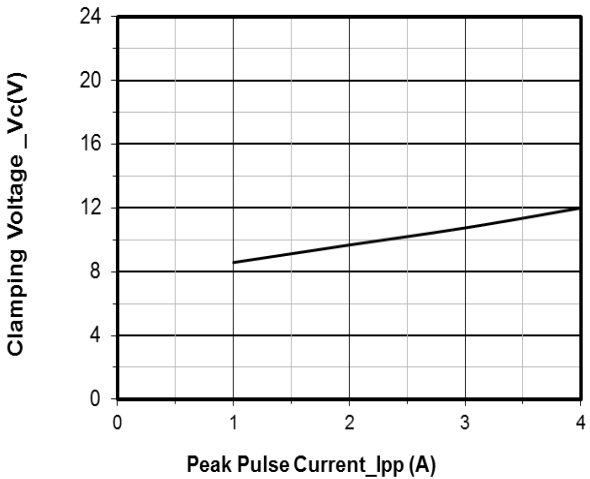

Clamping Voltage vs. Peak Pulse Current

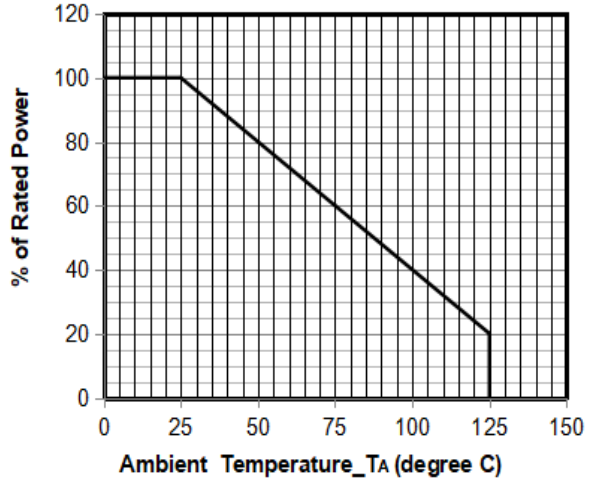

Power Derating Curve

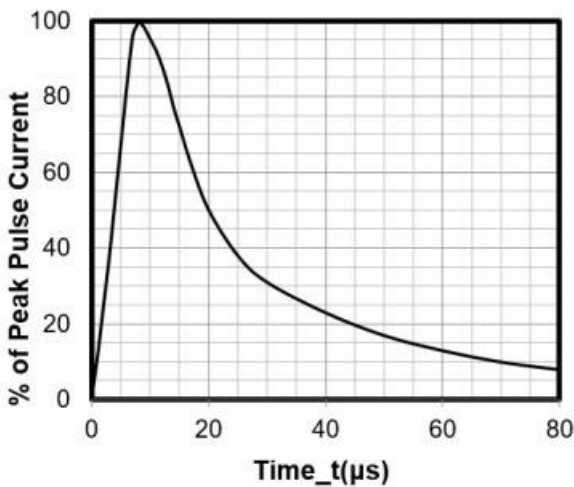

8 X 20μs Pulse Waveform

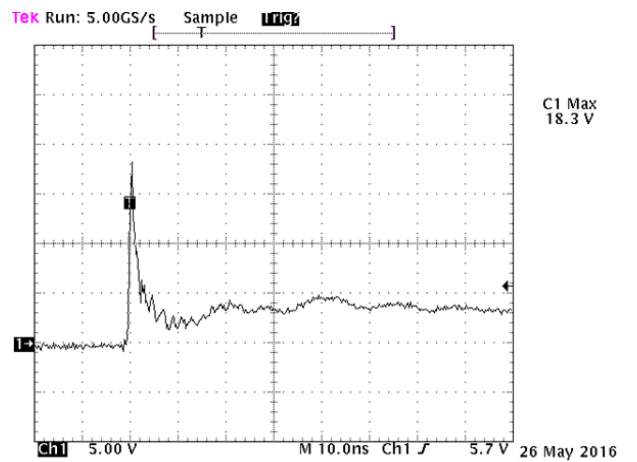

**Note: Data is taken with a 10x attenuator
Contact discharge current waveform
per IEC61000-4-2**

DFN2510-10 Package Outline Drawing

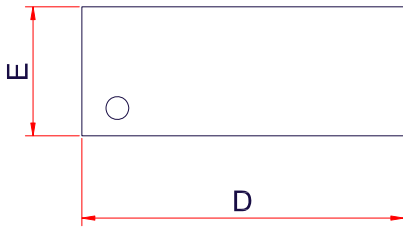

TOP VIEW

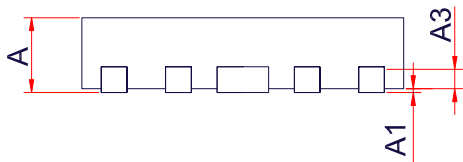

SIDE VIEW

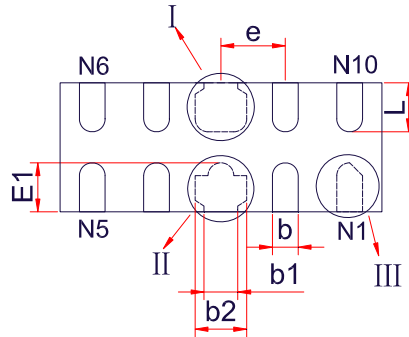

BOTTOM VIEW

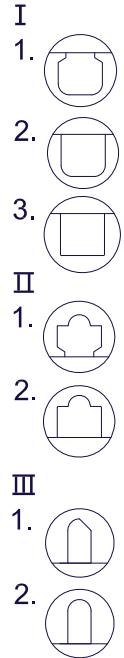

Recommended Land Pattern (Unit: mm)

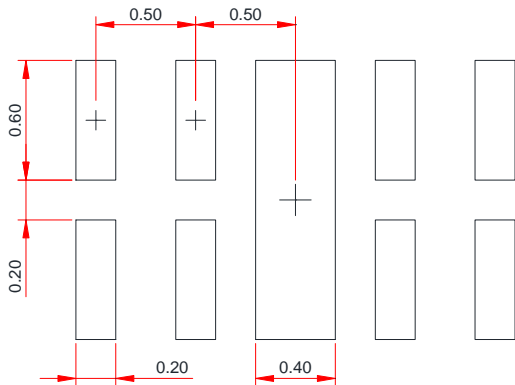

Symbol	Dimensions in millimeter		
	Min.	yp.	Max.
A	0.5	0.55	0.60
A1	0.	0.02	0.05
A3	0.1 Ref.		
D	2.4	2.50	2.60
E	0.9	1.00	1.10
E1	0.5 Ref.		
b	0.1	0.20	0.25
b1	0.13	0.18	0.23
b2	0.35	0.40	0.45
e	0.50 BSC		
L	0.2	0.39	0.50

Notes:

This recommended land pattern is for reference purposes only. Please consult your manufacturing group to ensure your PCB design guidelines are met.